



**A Beginner's Guide
To
Beekeeping in
Kenya**

By
Thomas Carroll, Msc. (Agr.)

Nakuru, Kenya
June 2006.

ACKNOWLEDGEMENTS:

I would like to thank my wife Jane and my three children – Mick, Kieran and James for supporting me to write this beekeeping guide and for putting up with dad being in the office (alot!).

I would also like to thank the Principal and staff of Baraka Agricultural College, Molo, Kenya for all their help and for giving me the opportunity to work on beekeeping development with them since 1994.

In addition I would like to thank Self Help Development International who support our beekeeping work at the college and also to Gorta who are currently supporting my beekeeping research work for my doctoral studies at University College Dublin.

I hope the guide is useful to those who want to start beekeeping in Kenya and other African countries. Beekeeping has the potential to earn significant amounts of money if carried out well and knowledge is the key to good beekeeping!

This book was written to assist beekeepers in Kenya and other African countries improve their beekeeping. It is written in simple language and is intended to be as practical as possible. The book is based on an earlier version called ‘Beekeeping a Beginner’s Guide’ which I wrote in 1997.

Please send comments on how this book can be improved and made more relevant so that future editions can be improved.

Send comments to tcarroll@apiconsult.com

By post to: Box 12173, Nakuru, Kenya

Thank you for helping to make future editions of this book better!

**Tom Carroll,
Box 12173, Nakuru,
Kenya,
June 2006**

About The Author:

Tom Carroll was born in Co. Laois, Ireland where he grew up on the family farm. He developed an interest in beekeeping at an early age when he found abandoned bee hives and equipment belonging to his late Grandfather in his home garden. His interest developed further when his father hired a local beekeeping expert to remove bees from the roof of the two storey family house. This beekeeper was old and too stiff to climb the ladder to remove the bees so he dressed young 9 year old Tom in a beesuit and sent him up the ladder to remove the bees. Tom loved it!! From there sprang a life long passion for bees which would change his life and take him half way round the world.

In 1993 having finished University in Dublin with a Master's degree in agriculture, Tom came to Kenya to work on a beekeeping development project. For the last 13 years Tom has worked on African beekeeping development in a number of African countries including Kenya, Somalia, Sudan, Uganda, Tanzania and Zambia.

In the year 2000 Tom set up www.apiconsult.com a website to assist the development of beekeeping in Africa through sharing ideas and information. Tom also shares the beekeeping knowledge and experience he has gained through this beekeeping guide.

This guide can be purchased as an e-book through the apiconsult web site. Hard copies of the book can be ordered by e-mailing tcarroll@apiconsult.com and a hard copy (spiral bound) will be posted on order.

CONTENTS

Introduction

Part One:

Introduction to Beekeeping - Page 6

The bees themselves; what is beekeeping; What do bees do; what is honey; what is beeswax; what is propolis; who lives in the beehive.

Part Two:

Getting Started - the Basics - Page 11

What is a hive; The Kenya Top Bar Hive (KTBH); The mud/stick hive; Where to put the Apiary; Hanging or placing the hives; General apiary management; Bee-Keeping equipment and how to use it; handling bees; What if no bees enter the hive? ; What causes absconding and its control.

Part Three:

The Beekeeping Year - Page 32

Conditions for maximum honey production; Beekeeping in Kirinyaga; Beekeeping in Kakamega; Beekeeping in Molo; Beekeeping in Transmara; Beekeeping in Nandi hills; Bee management during the year - swarm prevention and control, making a division, feeding, pests and diseases and their control; Major nectar bearing plants in Kenya.

Part Four:

The Harvest - Page 46

Time of harvesting, harvesting procedure, honey refining, extraction of beeswax.

Part Five:

The Market for Bee Products - Page 52

Honey - crude, semi-refined, refined, chunk, comb, packaging and labelling, where to sell the honey; beeswax; propolis.

Part Six:

Starting a Beekeeping Enterprise Costs and Profit - Page 55

Expenditure; income; net income; gross margin analysis

Appendices: - Page 58

Appendix one:	The current status of the Kenyan bee industry
Appendix two:	Information on stingless bees
Appendix three:	Hive record keeping
Appendix four:	Recipes/uses for beeswax, propolis and honey
Appendix five:	Sources of further information
Appendix six:	Beekeeping resources on the internet
Appendix seven:	Recommended reading/references

INTRODUCTION:

An introduction to beekeeping and this manual:

The purpose of bee-keeping is to produce and sell as much honey as possible. Beekeeping is a means to diversify livelihoods and make the best use of resources available to us. A diversified livelihood is a more secure one.

Beekeeping also has immense benefits in terms of provision of pollinators which enhance crop yields. Bees are environmentally friendly and so are beekeepers. I have seen many beekeeping groups initiate tree nurseries as they realise the importance of enhancing the environment to improve their honey yields. Also beekeepers are the most active in safeguarding natural environments as they know their honey crops are dependant on local vegetation – mostly trees, as their source of nectar.

Better beekeeping requires good management of the bees and of the hives. Anyone, young or old, men or women, can keep bees. Beekeeping needs very little land, time or equipment. It is an ideal activity for small scale farmers in Kenya and other African countries.

Farmers who want to keep bees generally have two fears:

1. A lack of information about bee-keeping

This is a common problem – where can they get relevant information?

2. A fear of bees

Many people have started beekeeping only to run into problems with excessive stinging of bees resulting in the farmer getting rid of the bees. Knowledge on how to keep and handle bees properly can overcome this problem.

This book will assist you with information on beekeeping and this will help you overcome your fears.

A Note on exchange rates:

In this book Ksh refers to the Kenyan Shilling and the exchange rates at the time of writing are 1 USD\$= 72Ksh 1Euro € = 92Ksh

Part One:

Introduction to Beekeeping

The Bees Themselves:

Honey Bees:

There are many different species of bees in the world – most of them solitary or live alone. A few species of bees are kept to produce honey. In Kenya the most important species is called the honeybee or *Apis mellifera*. This is the species of bee that is familiar to everyone. It is this species of bee that this book is about. Within this species there are a number of races of bees in Kenya which have their own particular characteristics. We have *Apis mellifera scutellata*, *Apis mellifera monticola*, *Apis mellifera yeminitica (nubica)* and *Apis mellifera littorea*.

1. *Apis mellifera yeminitica (formally A. m. nubica)*: This is the smallest race in Africa. It has the most slender abdomen and the largest yellow abdominal colour band of all African races. It most withstands and survives drought conditions by excessive migration. It is mostly found in the northern parts of Kenya.
2. *Apis mellifera scutellata* The bee is highly aggressive and has a great tendency to reproduce and migrate. It is found in plains and their high reproductive rate is attributed to massive flowering, which occurs in the plains just before the rains.
3. *Apis mellifera littorea*: The bee inhabits the low lands of the Kenya Coast. It does not migrate as much as *scutellata*. It has a tendency to rear brood through out the year due to availability of forage along the coast.
4. *Apis mellifera monticola* This bee is called the mountain bee. The bee inhabits places where the sun is frequently obscured by clouds and mist and ground frosts at night. It is the largest bee in Africa. It has a tendency to reduce brood rearing at the first sign of forage decline and may not migrate. It is less productive and less vicious. Found in Meru and Mt. Elgon. (Source National Beekeeping Station, Nairobi)

The bee races the writer is most familiar with are *A. m. monticola* which tends to be in the highlands and more docile. We probably have these around the Molo area. Also *A.m. scutellata* which is a smaller and more aggressive bee and found in the lowlands of Kenya – in our immediate vicinity we have in Baringo District. We may also have hybrids of these two types.

Stingless Bees:

There are also species of stingless bees in Kenya. These bees also produce honey which is prized as a medicine. Stingless bees can be kept in small hives but are not kept commercially in Kenya at the moment. However there has been renewed interest in these bees recently

with the discovery of new species in Kakamega by a scientist working for the National Museums of Kenya.

See appendix two for more information on stingless bees in Kenya.

What is Beekeeping:

Beekeeping is the art of managing bees in order to obtain honey, beeswax and other bee products for both food and income (and sometimes medicine).

Beekeeping can be carried out by men and women of any age (however in some Kenyan communities there are taboos against women handling bees).

It is also an ideal activity for groups such as women's groups, youth groups, men's groups, church groups etc. as an income generating activity. We have seen a number of very active youth groups involved in beekeeping – the youth can generate income without having to own land which can be a major constraint to other income generating activities.

Beekeeping requires little space and compliments other farm activities.

Beekeeping does not need good soil.

What do Bees do?

Bees do not compete with livestock for food.

Bees help the pollination of flowers, plants and crops.

Bees help to increase the quantity and quality of flowering crops (coffee, papaw, banana, avocado, macadamia, mangoes, etc.).

Bees fly 3 km from the hive so you benefit from other people's flowers.

Bees produce honey, beeswax and propolis (used in medicines) and other products such as royal jelly, pollen, bee venom and bee brood. Honey, beeswax and propolis are the three products currently exploited in Kenya and are dealt with in this book as they are the most important.

What is Honey?

Honey mostly contains sugars (80-85%) that are easily absorbed by the body (good for young, old and sick). Honey is made from nectar which is a sugary secretion of flowers. Nectar contains 70-80% water. To make honey the bees add enzymes and reduce the water content to that of honey (good honey contains less than 19% water).

Honey is a very good energy food - use it as a sweetener for food (cake, chapatti, bread etc.) and drink (try some in your tea!).

Honey has medicinal properties -Use it to help coughs, ulcers, wounds and sore throats (see recipe for honey cough syrup in appendix 4).

Honey has a high market value– It is used to make local beer and is also a food preservative.

Honey is always in demand - It is a good source of cash.

What is Beeswax?

Beeswax is the substance bees use to make their combs. It is secreted by special wax glands on the abdomen (bottom) of worker bees.

Beeswax is used in cosmetics, soaps, preserving leather and wood, candles, ointments, batiks, shoe polish and foundation sheets for Langstroth hives.

You can learn to turn honey combs into wax. Simple instructions and recipes for using the wax are given later in this book (appendix 4).

With a little training you can make candles and shoe polish for sale.

What is Propolis?

Propolis is a resin that bees collect from plants. It is black and sticky.

Bees use it to cover the inside of the hive and fill in the cracks.

It is an antibiotic and is used as a medicine.

If you chew propolis it tastes bitter, but it is good for the throat and the chest. There is an export market for propolis. Appendix 4 has a recipe for making propolis ointment.

Who Lives in the Beehive?

In the beehive the mother is called the **Queen** and the father is called the **Drone**. The third type (or caste) of bee is the **Worker** which is actually an immature female.

The Queen Bee

The Queen is a sexually mature female.

There is only one Queen in the hive and her job is to lay eggs which hatch into other bees. She can lay up to 2,000 eggs per day.

She may be hard to find in the hive but you can recognise her by her length. She is long and slender and her wings only reach half way down her back. She is far bigger than the numerous workers, but do not confuse her with the drones.



Queen

Figure 1 - the queen bee

The Drone

There can be several hundred Drones in a hive. The number depends on the time of year. In times of food shortage the drones are thrown out of the hive by the workers. When a new Queen starts life, she mates only once with up to 10 Drones outside the hive, high up in the air.

Drones have very large eyes which are used to spot the Queen during mating.

The Drones' major task is to mate. They have no sting.

Drones look large and square and make a loud buzzing noise when they fly.

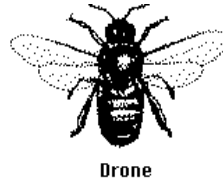

Figure 2 - the drone or male bee

The Workers

Most of the bees in the hive are Workers and they do all the work.

Workers collect the honey/pollen/propolis, feed the young, feed the Queen and guard the hive. They have a sting. Workers can number up to 60,000 in a very strong colony (hive) of bees.



Figure 3 - the worker bee - does all the work in the hive

The Young (brood):

When the Queen lays an egg it looks like a grain of rice. To see the eggs hold combs from the centre of the brood nest (at the centre of the hive) up to the light. Look carefully at apparently empty cells they usually have eggs at the bottom.

The egg develops into larvae which look like a white maggot. The larvae are fed on pollen/honey. **Pollen** is the powdery substance produced by the anther of flowers and is rich in protein. Pollen is the coloured substance seen on bee's legs and stored in the combs.

The larvae are later sealed in the comb where it turns into an adult bee. During this changing process it is called a pupa. Thus there are three stages to adulthood: **egg - larvae - pupae - adult**.

Editors Note: Learn the difference between capped brood and capped honey. Capped brood is usually dark brown. Capped honey is usually white or creamy.

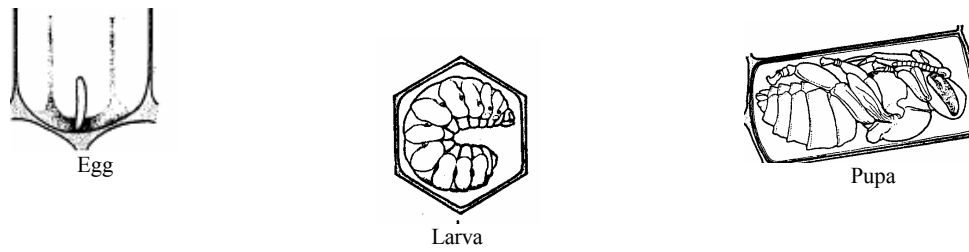

Figure 4 – Egg, Larva, Pupa

Bee Caste	Eggs to Larvae (days)	Larvae to Pupae (days)	Pupae to adults (days)	Total days egg to adult
Queen	3	4.5	7	14.7
Worker	3	4.25	11.25	18.5
Drone	3	6.5	14.5	24.0

Table 1 – time spent in each stage of development

Part Two:

Getting started - the basics

What is a Hive?

A hive is the box or container where the bees live. Without a hive you cannot be called a beekeeper!

Different types of hives are used in beekeeping. Here are some:

- * Pot hives (clay pots)
- * log hives,
- * basket hives,
- * Kenya Top Bar Hive (KTBH)
- * Langstroth hives (uses frames)

Log hives are made from hollowed out tree trunks.

Basket hives are made from woven sticks which are smeared with mud.

In this book we will give you the measurements of the KTBH hive and a cheaper mud/stick hive which also has top bars. We do not deal with the more complicated Langstroth frame hive in this book as we don't believe that it is the best option for beekeeping beginners in Kenya.

Once you have experience in beekeeping and once you understand why you should purchase a frame hive (and have to money to do so) then by all means use the frame hive. However you should be aware that there are no automatic increased yields from having a Langstroth. The hive is only as good as you manage it! The writer has produced up to 40kgs per KTBH, many people who have purchased Langstroths have produced little or nothing. So understand the bees and bee management and you will produce good crops of honey no matter the type of hive you have.



Photograph 1- a pot hive with a 'super' or honey chamber on top



Photograph 2 – Log hive covered with Bark – Koibatek district, Kenya



Photograph 3 - Box hives – simple boxes in which the bees build their combs, Londiani, Kericho District, Kenya



Photograph 4 - a wild colony of bees nesting in a roof



Photograph 5 - a KTBH on the left and a Langstroth on the right – Turkana District, Kenya

The Kenya Top Bar Hive (KTBH)



Photograph 6 - a brood comb from the Kenya Top Bar Hive (KTBH)

Figure 5 on the next page shows the construction drawing of a Kenyan Top Bar Hive. Remember follow the measurements!

***Important -You must copy exactly the measurements we give you.**

When it comes to bee management, it is important that all your hives are the same size.

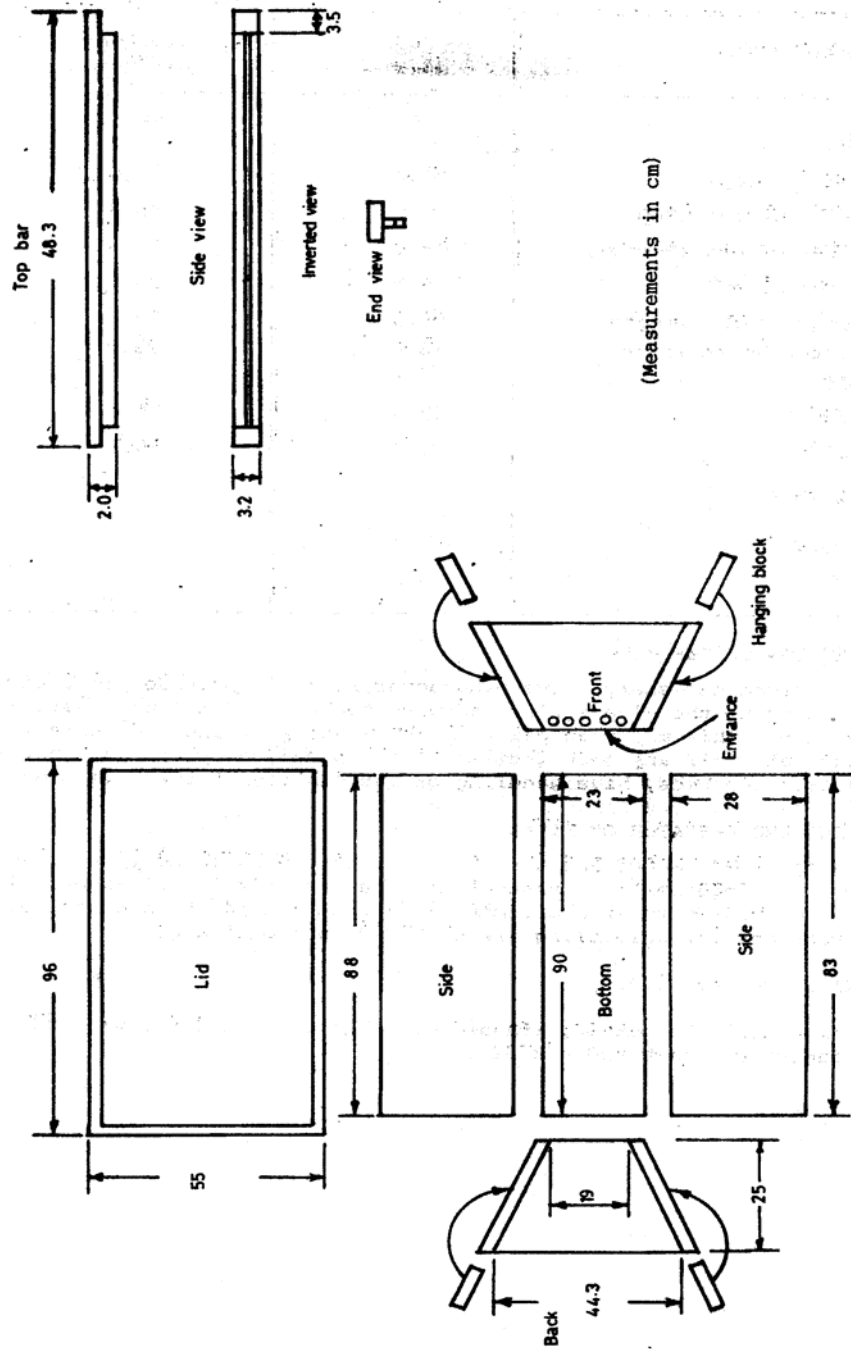

FIG. 1 - KENYA TOP BAR HIVE (Based on 2 cm lumber)

6

Figure 5 - Drawing of the KTBH hive

Source: *Beekeepers Guide Book – National Beekeeping Station, Nairobi*

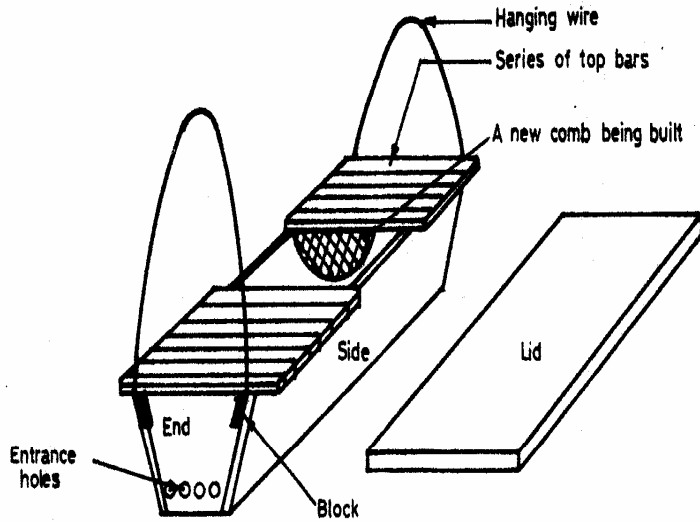
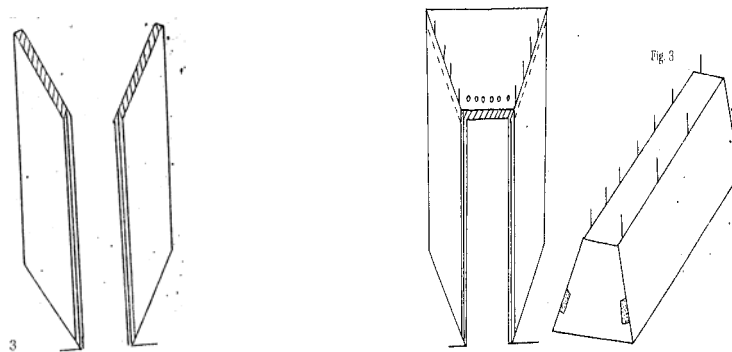

FIG. 2 - KENYA TOP BAR HIVE (KTBH)

Figure 6 - Assembly of the KTBH



Source: *Beekeepers Guide Book – National Beekeeping Station, Nairobi*

Tips:

- Use dry timber to prevent cracking and warping.
- Use whatever timber is cheap and available locally. Pine, Cyprus, *Grevillia robusta* are commonly used but if you have your own wood, use it.
- Try to get the hive body of the KTBH the right size.
- It is VERY IMPORTANT to follow the measurements of the top bars exactly. The top bars are made a specific measurement to make sure that the bees build one comb per each top bar making the combs easy to inspect.
- Top bars should be the right width and fit the hive body well.
- Don't forget to wax your top bars to attract the bees. A simple way to do this is to use a paint brush to paint on melted beeswax onto the protruding ridge at the Centre of the top bar. The strip of wax helps to guide the bees to build straight combs which can be inspected and harvested easily.
- All parts of the hive should fit together properly and there should be no holes.



Photograph 7 - working with bees in a KTBH - Molo, Kenya

The Mud/Stick Hive

A Mud/stick type hive. This is the answer to all of you who say you have no money to start! No excuses allowed!



Photograph 8 - the hive body is made from sticks with holes filled with mud - Molo, Kenya

For the mud/stick hive use the same dimensions as the body of the KTBH - same length, width, height. However make the body square. For the body use about 50 long and 30 short straight sticks. Make a frame of sticks initially for the bottom (or you can also make a timber frame and add sticks as in the hive shown in the photograph). To this tie/nail on other sticks to the frame. Use wire to tie all the sticks together. If you bind them tightly then you can have a very strong frame. Plaster the frame with mud and cow dung and leave to dry. The top bars fit along the top of the hive just like the KTBH. Remember to make some small holes at one end of the hive as the entrance. As a roof you can use 'Mubate' (tin) – however the mud/stick hive works best under shelter such as a bee house due to potential damage from heavy rain – if inside just use a sack for a cover.

Tips:

- Shelter the hive from heavy rain.
- **Important: make the top bars the same measurement as the KTBH – this allows bees to be transferred from one type of hive to the other.**

The above two designs of hive are an improvement of the traditional log and basket hives because with top bars, combs are moveable. This allows management of the bees. Yet top bar

hives are not as expensive or difficult to manage as Langstroth hives which makes them more suitable for use by small scale farmers.



Photograph 9 - this top bar hive body is made from concrete - Zambia

You can also be innovative and use other materials to make the hive body. The above photo shows a concrete KTBH hive which works very well. The above pictured hive is under a grass shade cover to keep out the rain and hot sun.

Where to put the Apiary?

An apiary is a place where hives are kept. Try and keep a limit of not more than 20 hives per apiary depending on the availability of bee forage. Bees forage in a radius of 3km from the apiary so if you want to keep more than 20 hives find another apiary site 3 or more kms away from the existing apiary. Plant a good high hedge around your apiary using a shrub such as Keiapple. As you wait for the fence to grow you can use off cuts (waste timber from a saw mill) to make a fence. The hedge separates bees from people and animals.

Choosing a good site to hang your hives is very important.

- If you choose a poor site people and animals may be stung.

- If the site is insecure honey and hives can be stolen.
- If you live in a hot area your hives will need shade as well as water.
- If you live in a cool area, such as the highlands, only minimal shade is required or the bees will be cold and damp.

An ideal site to set an apiary would be:

- Away from human/livestock dwelling areas, roads and public areas.
- Safe from strong direct sunshine, windy areas and theft.
- Accessible to water and bee plants nearby.
- Away from swampy areas and smelly places.
- Near a good source of nectar such as forest/trees/nectar bearing crops.

So now you have made a hive or two. Did you follow the instructions carefully? Are your top bars the right measurement? You have also chosen the site for the apiary - if you are still not sure ask someone who knows. Remember once the bees enter the hives it will be more difficult to change things, Right! Now we come to how to put the hives in the apiary.

Hanging or Placing the Hives

Hanging hives:

(Do not hang the mud/stick hive as it is not strong enough - see below for placing).

- Use two strong and heavy posts, each about 2.5 to 3 meters long.
- Dig two holes about 3/4 of a metre deep and 2 meters apart (or take two strides).
- Pack soil and stones around the posts. Make sure the posts are very firm. Think ahead to when the hive will be heavy with honey - if they are not firm they will fall over later.
- **Remember:** once bees enter the hive it will be difficult to make changes!
- Now that the holes are dug and the posts are in position, use wires to hang the hive between the two posts.
- **Remember:** put the wire around the back of the posts as shown in fig.7 below.
- **Remember:** hang the hive at waist height (for ease of working and not to strain your back) and keep it level.

Take time do things properly and you will be glad later on!

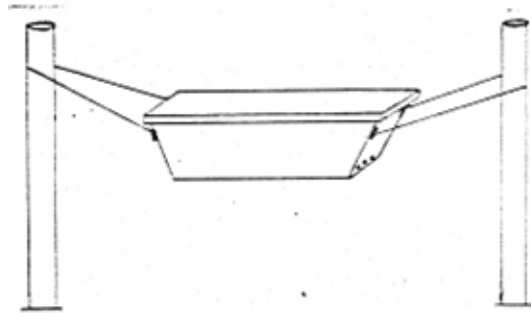

Figure 7 - hanging a KTBH posts - 2 meters apart and the hive 1 meter from the ground



Photograph 10 – KTBH hives hanging in the foreground and another on a stand in the background (with stone on lid to keep the wind from blowing the lid off)

You can also hang hives between two trees or a post and a tree. Just follow the same instructions but remember to use heavy strong nails. When hanging more than one hive you can follow some of the patterns below:

Figure 8: hanging patterns for Kenya Top Bar Hives:

□ = a hive

○ = a hanging post

1. Line pattern:

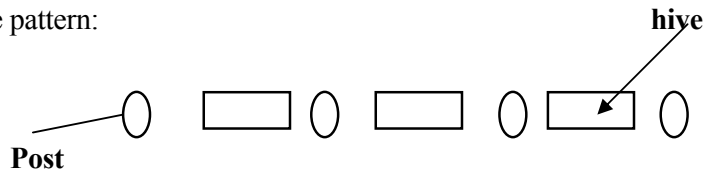

2. Cross pattern:

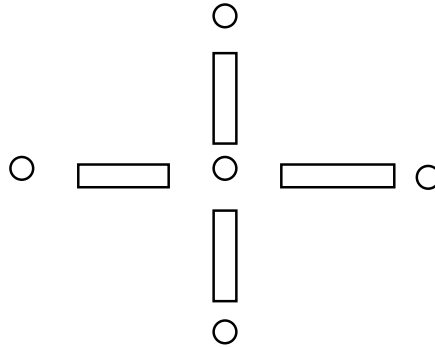

3. T - pattern:

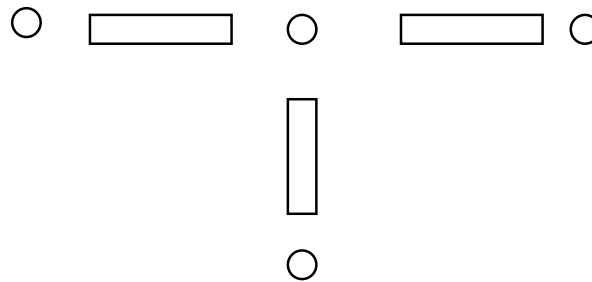

Hive placing:

- If you don't want to hang the hives, you can place them on stands. It is best to use this method for the mud hive as it is not strong enough to hang.
- **Remember:** the stand should be sturdy and high enough for the hive to be at waist height.
- Put the legs of the stand in cans of used engine oil to prevent pests getting into the hive.
- Hives on stands are more prone to attack by the honey badger (see pests and diseases).



Photograph 11 - concrete top bar hives in Zambia under a shade

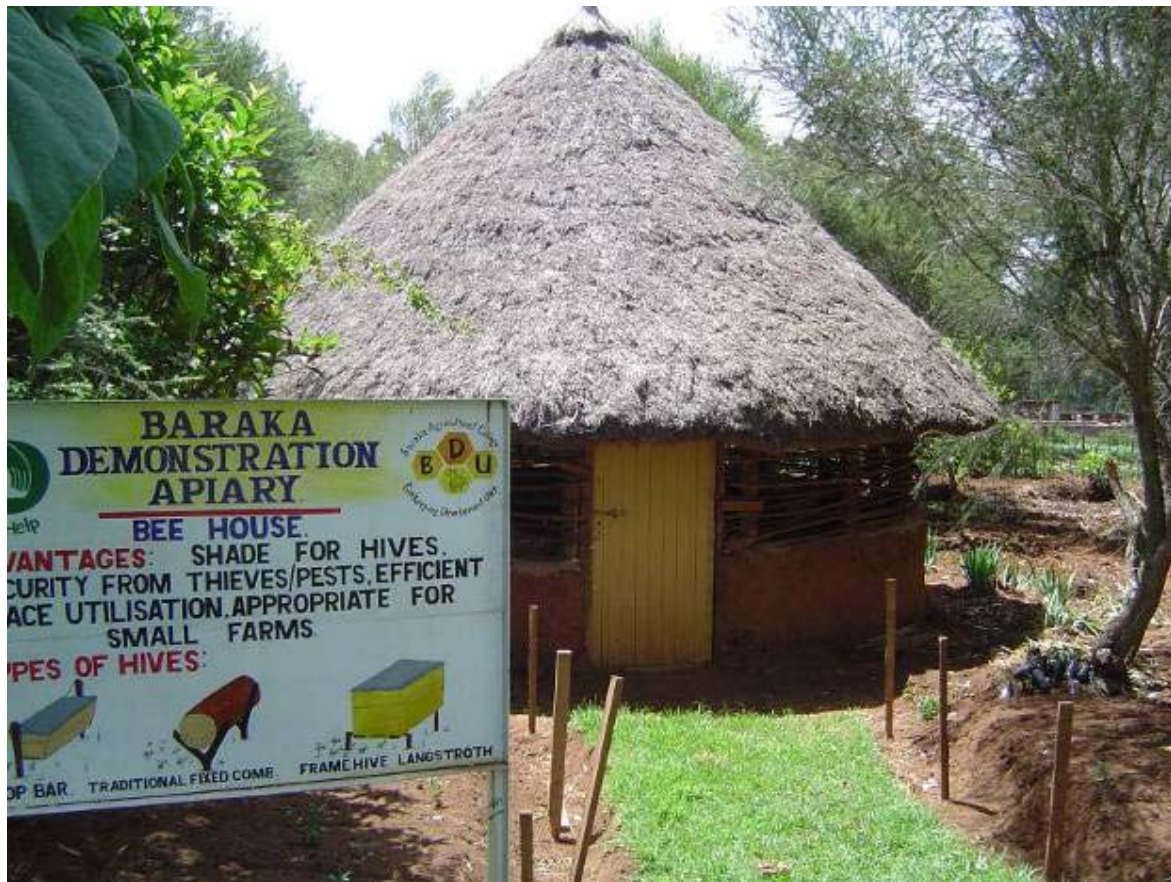

Photograph 12 - the bee house at Baraka Agricultural College, Molo



Photograph 13 - farmers in Koibatek inspect a newly constructed bee house with Ministry of Livestock staff



Photograph 14 - this apiary is fenced with off-cuts to screen bees away from people and animals - Nakuru, Kenya

Note:

*Putting a number of hives under a shelter or into a **bee house** is also an option as show in the photos above. Just make sure that the bees have a way of getting in and out to their hives. A bee house is useful because it can be locked to prevent thieves stealing the honey. A bee house can be a simple mud hut with holes in the walls for bees to come and go.*

General Apiary Management:

1. Keep the apiary clean: cut grass short and trim branches that reach the hives to prevent pests like ants from crawling into hives and disturbing the bees.
2. Grease wires holding hives to keep off crawling pests - particularly ants.
3. Do not make noise around the apiary, particularly machinery, as it can agitate bees.
4. Supplement the bee's source of nectar by planting certain plants around the apiary i.e. Bananas, Sunflower, Mango trees, Citrus, Coffee, Eucalyptus, Paw paws, Passion fruits, Croton, Acacia, Bottle brush and Calliandra etc. Trees will also give shade to the bees and provide a screen between them and people and animals nearby.
5. Remove old combs from the hive. This helps to prevent wax moth damage.
6. Do not spill honey near the apiary. It will attract pests and cause the bees to fight with their neighbours (bees from other nearby hives).
7. Inspect hives regularly to monitor the progress of the bees and ensure no pests are attacking them (see later for the list of pests)
8. When the bees are making honey, inspect the hives once a week by opening them up. At other times inspect hives every month. Simply looking at the hives (without opening them) can be done almost daily.
9. Observing the bees for a few minutes can tell you a lot. Are the bees collecting pollen? (This is the coloured substance on the legs of workers). If they are, it indicates that the bees are feeding the young. It shows that the bees are healthy and have a laying Queen.

Bee-Keeping Equipment and How to Use It:

- a) **Hive** - for housing bees. (KTBH or other form as already mentioned). The hive is the most important piece of beekeeping equipment. Without a hive you cannot be a beekeeper!
- b) **Bee-suit** - Consists of the following items:
 1. Veil: for covering head and face and giving protection from stings.
 2. Overall: for covering the rest of the body
 3. Gloves: for covering the hands
 4. Gumboots for covering the feet.
- c) **Smoker** - The smoker is a vital piece of equipment. Smoke from the smoker is used to control the bees and keep them from becoming aggressive when they are handled. When lighting a smoker use dried grass to light it and when it is burning well put in some damp grass so that it gives a thick cool smoke. Do not allow the smoker to spark or have flame which will burn the bees. An alternative smoker fuel is dry cow dung. Careful when extinguishing the smoker that you do not start a fire!

The above are the most important pieces of equipment. These can also help:

- d) **Catcher box**- For transferring bees from one place to another - it's a miniature hive.
- e) **Hive tool**- For lifting top bars. The hive tool can be improvised by using a strong knife.
- f) **Bee brush**- For brushing bees from combs when harvesting honey or at any other time you need to remove bees. You can improvise by using a feather.

Beekeeping equipment: The most important are – bee suit (including overall, veil, gloves and gum boots), the smoker, bee brush and hive tool. Also a harvesting bucket is essential and a knife for cutting combs when harvesting.



Photograph 15 - the smoker



Photograph 16 - bee brush on the left and a hive tool on the right



Photograph 17 - good gloves are essential working African bees



Photograph 18 – A boy aged 8 years working African bees in Nakuru, Kenya wearing a full suit, gloves and gum boots. If a small boy is not afraid - why do so many adults fear bees?

Handling Bees:

- Many people are afraid of bees because they sting. All of us have heard of stories where bees attacked, and even killed, people and livestock (African bees can be very aggressive and need to be handled carefully). Like other forms of livestock, bees must be handled with respect and care. If handled properly, bees will not cause any problems.
- Some bees tend to sting less than other types. A beekeeper who frequently inspects his hives can easily tell those bees which are better and more docile. He can then eliminate the more aggressive bees and breed from the docile ones. (Not all African bees are aggressive – I have worked bees in Northern Somalia which were very docile and didn't require a veil!).
- With frequent handling bees appear to become 'used' to being inspected and therefore less aggressive. A beekeeper can come to know the character of his bees. If you have many hives number them and keep records at each inspection of the bee's behaviour. Eliminate aggressive colonies.

When Handling Bees:

- Always wear a bee suit and take the time to put it on properly. Many people do not do this and get stung when the hives are open. There is no need for this. If you don't know how to do it, get someone to help you (your experienced friend).
- Avoid wearing woollen clothes because they agitate bees which become stuck in them.
- Avoid drinking alcohol, using strong smelling soaps or sprays all of which may aggravate the bees.

- Always use a smoker when handling bees. Smoke makes the bees suck honey from the combs and calms them down (it also masks alarm smells the bees use to communicate). Do not let the smoker go out during the operation or the bees can become aggressive. Keep plenty of smoker fuel handy as you work. It is always better to have two smokers alight than one, in case one goes out.
- Start with the least aggressive colonies always. This will allow you to work in peace with the pleasant colonies first.
- Work gently and quietly. Do not knock or bang the hive as this can make the bees angry.
- Always handle the bees in the evening between 5.30pm and darkness (initially be careful – once you know your bees and how aggressive they are – you will know the best time to handle them). If the bees become aggressive at this time then they have a chance to cool down before the following morning. They also seem to be less aggressive in the cool of the evening. For bees which you have never handled before, or for very aggressive bees, take the extra precaution of handling the bees at dusk using a torch to see the bees.
- When handling avoid crushing the bees and making sudden movements. Work carefully and with confidence. Remain calm even if the bees become aggressive. If bees appear to be getting out of control, close up the hive and try again another day. If bees get into your veil - remain calm - walk to a safe distance before trying to rectify the problem.
- Work the hives with two or more people at a time. One person can lift out the combs while the other uses the smoker. This allows better control of the bees.
- Do not stand in front of the hive entrance when examining the hive. Bees flying in and out may become agitated to find their way blocked. Always cut down disturbance to the bees in every way you can.
- Advise any onlookers to move away quietly if stung covering their eyes. No running about waving the arms as this can annoy the bees.
- Remove bee stings from the skin as soon as possible using a hive tool or your nail to scrape off the sting. Trying to pull out the sting tends to squeeze in more venom. Use smoke to cover the scent of a sting. When a bee stings this scent will attract other bees to sting you again if you do not use smoke.
- On finishing the job close up the hives. Do not go directly to where you are to remove your beesuit. Take a route via bushes or tall maize sugarcane etc. if around. Rub yourself against the leaves to rid yourself of bees which might be following or on you.

In time, as you gain experience as a beekeeper, you will be able to judge the mood of the bees more accurately and handle them calmly. However for the first few times it is better to get a friend to help you.

Warning: *Some people can get an allergic reaction to bee stings. The normal response in most people is some localised swelling. If you see someone who has swellings all over the body and has difficulty in breathing take the person immediately to the doctor for treatment. Severe allergic reactions to bee stings can be fatal. However such cases are rare. For most people a few stings may actually be beneficial. Bee venom is used to treat arthritis and can be extracted from bees commercially. Contact ICIPE Nairobi for further information on bee venom (address in appendix 5).*

What if no Bees enter the hive?

It often happens that bees do not enter the hive for quite a while. The new hive that you have worked so hard to build stays empty. An empty hive does not produce any honey! A survey of beehives in Kakamega and Kirinyaga revealed that hive occupation varied between 40 and 70%. A recent survey in Kitui by DANIDA (2005) revealed occupation rates of between 30 and 75%. At a farmer's research meeting at Baraka Agricultural College in 2006 three different groups of farmers working separately came up with low hive occupation rates as their biggest threat to beekeeping.

Check the following:

- Have you waxed your top bars as shown?
- Is the hive clean and pest free?
- Are there any ants or rats nesting in it? If so, clean it out and re-grease the wires. Bees do not like a dirty hive.
- Is it the swarming season? Ask a friendly beekeeper in your area. Swarming is when bees reproduce themselves and fly out of the old hive looking for a new home. During the swarming season it is easier for hives to be occupied quickly. In Kerugoya town in 1995 two hives at our extension office were occupied by bees before we had time to hang them!
- Have you chosen a good site for hanging the hive?
- But what if it is not the swarming season? Even if it is, and bees are still not entering the hive, what can you do? Well bees can be put into the hive by the beekeeper. There are different ways to do this:

A. Catch a wild swarm of bees:

For this operation it is best to seek help from an experienced friend. The swarm has a better chance of staying in its new hive if it is during a nectar flow. Don't waste time with very small swarms smaller than a person's head as they are more trouble than they are worth.

- Prepare your hive first by smearing it with some melted beeswax so it smells nice for the bees.
- Use your smoker and beesuit, some swarms may be hungry and difficult to manage. Always be careful with strange bees!

- Look for a swarm of bees clustering on a branch where you can catch them. Wear your bee suit and smoke the bees very gently so as not to disturb them (don't smoke if you can avoid it). Shake the bees into a catcher box or other container (such as a cardboard box). If the Queen falls into the box, the rest of the bees will follow. Wait 20 minutes or so. If the bees return to the original site, try again.
- Once you have the bees leave the box in a shady place until evening. Make sure the bees do not become hot in the container - covering it with a damp cloth can help.
- When evening comes, take the bees home. Shake the bees into your empty hive.
- If you have other hives give the bees a comb with some uncapped honey and a brood comb with eggs from another hive to encourage them to stay.
- However, at any stage in this operation the bees may decide they don't like being disturbed and fly away (African bees frequently abscond).



Photograph 19 - catcher boxes waiting to trap passing bee swarms - this location trapped 17 swarms in one season alone (Nakuru district)

B. Transfer bees into your hive:

- You can transfer bees into a top bar hive from a wild nest or from a traditional hive with fixed combs (combs which are not moveable).
- To do this cut out the combs one by one and tie them to the top bars of your hive. Get help on this one as it is not easy for the beginner.

C. Making a division of an existing colony:

You can also make a division of an existing colony. This is explained later under the section bee management during the year.

What causes absconding and its control:

Absconding is where the bees leave the hive completely. It is very frustrating for the beekeeper who has done so much to get the hive occupied.

Absconding and its prevention:

1. Lack of food and water for the bees - leave food for bees when harvesting; feed if necessary with sugar syrup; provide a source of water in the apiary.
2. Frequent attacks by pests - check your hives frequently - grease hanging wires to control ants.
3. Unfavourable weather conditions such as cold and rain - make sure the bees have enough food.
4. Careless handling by the beekeeper (breaking combs, over smoking etc.) - careful handling.
5. Genetic character of the bees - some bees are prone to absconding (don't breed from bees with this trait).
6. Excessive heat on the hive (no shade in very hot sun) - put hives in a well shaded place in hot areas.
7. Excessive cold and damp - don't put the hives under dense trees in high altitude areas - give them a sunny position with minimal shade.

Part Three:

The Beekeeping Year

Conditions for maximum honey production:

So far we have seen how to get started in beekeeping; how to make the hive, choose the apiary site, hang the hive and get the bees. Now let's look at the bigger picture. Let's see how the bees change throughout the year. It is important for the beekeeper to understand this because he/she can manipulate the bee colony to produce larger amounts of honey.

Figure 9: Conditions required for maximum honey yields

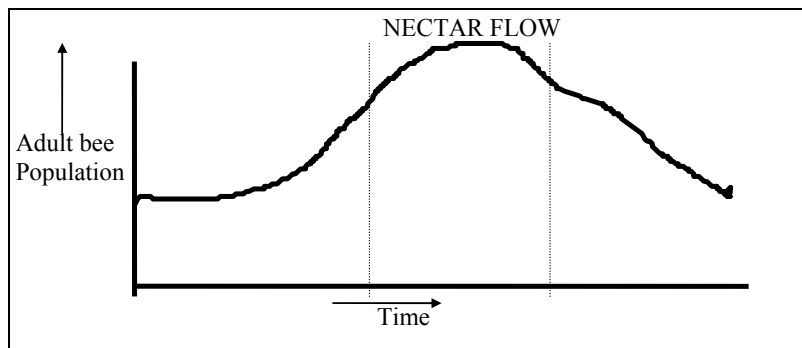

The chart shows that if the peak colony strength occurs at the time of the nectar flow a good honey crop can result – providing the nectar flow is good and the weather conditions are right.

Your main aim, as a beekeeper, is to get the peak colony strength at the right time.

Think about this. Imagine that the peak strength of the colony comes at a time when the flowers are finished. All the bees will be sitting in the hive with little work to do. Manipulating the colony to be at the peak strength at the right time is fundamental to good beekeeping. Good flying conditions (dry weather) for the bees is also important during the nectar flow to get maximum yields. This factor however is outside your control as a beekeeper.

The above graph also shows that the size of the colony changes over time. When food is plentiful there are more bees because the workers feed the Queen Bee more food and she lays more eggs. When food is scarce, the workers feed the Queen less and the colony numbers drop. The bees' behaviour is very sensitive to their environment. When there is plenty of food, bees make more honey to eat later on when there is less food. The beekeeper shares in this stock of food. Always remember when harvesting to leave some for the bees - don't be too greedy!

Example 1: The Beekeeping year in Kirinyaga:

As with most parts of Kenya, Kirinyaga district has huge variation in climate. It stretches from the top of Mount Kenya (snow capped) to the semi-arid Mwea division. In between there is tundra, bamboo, montane forest, tea and coffee zones. Conditions for bees vary widely in all

these areas. Such things as climate and vegetation can change totally over a few kilometres. As with changing environment, yield potential and harvesting seasons for bees vary widely. It is very important for a beekeeper therefore to be knowledgeable of his own environment where he keeps his bees because things change so dramatically over short distances.

In Kirinyaga there are two harvesting seasons - March/April and again in September /October. The yield of honey obtained at our office apiary in Kerugoya was on average 7.5kgs per hive per harvest or 15kgs of honey per annum/hive. The main nectar bearing trees in the area are coffee (*Coffea spp*), bananas (*Musa spp*), *Grevillia robusta*, avocados (*Persea americana*), macadamia (*Macadamia tetraphylla*), mangoes (*Mangifera indica*), Croton, papaw (*Carica papaya*) and beans (*Phaseolus vulgaris*). Flowering maize is an important source of pollen.

Hive occupation can vary depending on the time of year. Swarming season was observed to be in July. Bee swarms have been noted to migrate up from Mwea division to areas of higher altitude and visa versa depending on the time of year. However, bees at the office apiary in Kerugoya town have not migrated over the past year and a half perhaps because of little disturbance to them, in particular on harvesting. Also sufficient honey is left for them.

Mwea division, Kirinyaga :

Mr. Kariuki is a new settler in Mwea Division who has recently bought 3 acres of land. He has never owned a beehive. At one of the bee-keeping field days, Mr. Kariuki observed that most apiaries were sited under trees. He said he had no trees on his new farm, but asked which tree species he should plant to act as bee forage. He was given the following advice:

Grevillea robusta: Mukima (Gikuyu), Silky Oak (English); This is the most abundant tree in the district. The tree grows very fast. Produces allot of nectar. It flowers in March-April hence ensures honey flow in May and June. Other uses are fodder sources and timber as well as coffee shade, mulch and green manure. The tree is propagated by wilding and seedlings.

Acacia mellifera.Muthigira (Gikuyu); Hook thorn (English); A low shrub propagated by direct sowing, seedlings, coppicing and wilding. Flowering before the rains. The flowers produce quality honey. Other uses are fodder (pods, twigs, leaves and flowers), live fence and fuelwood.

Others of the same genus are

- *A. lahai* (Mugaa)
- *A. seyal* (Mugaa)
- *A. abyssinica* (Mugaa)
- *A. brevispica* (Mwikunya)(wait-a-bit-thorn)
- *A. gerrardii* (Muthi)

Eucalyptus saligna: Muringamu, Sydney blue gum,

The tree grows at an altitude of 1200 - 2400 m except in arid areas and areas infested with termites. It is propagated by seedlings and direct sowing. It flowers in June and July. The tree should not be planted near crops but should be planted as a woodlot.

Other useful trees and shrubs are:

- *Croton megalocarpus* (Mukinduri): flowers in March-April and useful for boundary marking, timber and shade.

- *Azadirachta indica* (Mwarubaini): flowers in March-April with seeds in June; useful as medicine, insecticide, shade, fertiliser and de-wormer.
- *Calliandra calothyrsus* (Calliandra): used also for shade and windbreaks as well as fodder. The shrub flowers in February-March
- *Callistemon citrinus* (Bottle brush): very fast growing and useful as well as ornamental.
- *Cajanus cajan*: (Njugu) a drought resistant food crop with other uses as nitrogen fixation agent, fodder (leaves and pods).
- *Kigelia africana* (Muratina), (Sausage tree): flowers in January-February. The unripe fruit is poisonous. Does well in arid areas. The Kikuyu do not plant it near homesteads as it was used to mark grave sites. It is a slow growing tree, a non-prolific seeder with a poor germination rate.

Cultivated varieties include;

Papaw	<i>Carica papaya</i>	Bananas <i>Musa sp.</i>
Beans	<i>Phaseolus sp.</i>	Muembe(Kik) <i>Mangifera indica</i>
Mubera(Kik)	<i>Psidium guajava</i>	Mukandamia(Kik) <i>Macadamia tetraphylla</i>

Mr. Kariuki was surprised to find he already knew all about the forage mentioned. He also learned that apiaries are sited under trees to make use of their shade. The Bee-keeping Officer appreciated Mr. Kariuki's wisdom in recognising the importance of bee forage trees as a first step to successful bee-keeping.

(Thanks to Gachuri R. N., Beekeeping Officer, Kirinyaga for the above piece on Mwea)

Example 2: The Beekeeping year in Kakamega:

The following is a brief description on the type of beekeeping practised, potential yields, flowering trees and seasonality of honey production around Kakamega.

There are three different types of hives used in the area namely:

- Traditional log hives
 - Kenya top bar hives (KTBH)
 - Basket hives
1. Log hives are made from trees species such as Munga, Likoro, Munuku and Mukomari (Luyhia language).
 2. KTBH hives are reputed to be very productive if managed well. However they may get too hot in the dry season and too cold in the wet season. Therefore they need to be insulated. Using grass for heat retention in the wet season is said to work well.
 3. Basket hives are least favoured by beekeepers.

Table 2: Beekeeper's preference for different types of hives around Kakamega forest:

1=best, 2= second best, 3= last

Factors:	KTBH	LOG	BASKET
Quantity harvested	2	1	3
Ease of harvest	1	2	3
Heat properties	3	1	2
Least cost (cheapest)	3	2	1
Resistance to rain	1	2	3
Durability	2	1	3
Total Score	12	9	15

Editor's note: The above table is a good lesson for those of us who promote improved hive designs. In the table the log hive comes out the best with the KTBH second and the basket hive last. If the KTBH hive is not managed to gain the advantages it has due to its moveable combs then it will be outperformed by the log hive. The advantages of the KTBH are many such as the ability to manipulate the bees to increase honey. Ease of harvesting will allow comb honey to be harvested which can obtain a significantly higher price in the market. A KTBH (or Langstroth) which is not managed, producing crude honey is actually worse than a log hive because of its higher cost to purchase.

The swarming season is reported to be in November.

Normally hives are harvested only once per year. Honey is produced by the bees from November to April but production is highest between December and March (see figure 10). One can get 30-40kg of crude honey per hive harvesting in February/March. Harvesting can take place more than once during this period. As the weather becomes cooler when the rains start in March/April the bees become net consumers of honey, so if harvesting is not carried out before the rains, yields will go down.

Honey production is reliant on the flowering of forest trees and other plants including *Leucaena leucocephala*, Bananas, Isungusa (Luyhia), Isirimoi (Luyhia), and Iludolio (Luyhia). The flowering of *Croton megalocarpus* (Musine, Luyhia) is an indicator of when to harvest.

Figure 10: Seasonality of honey production in Kakamega:

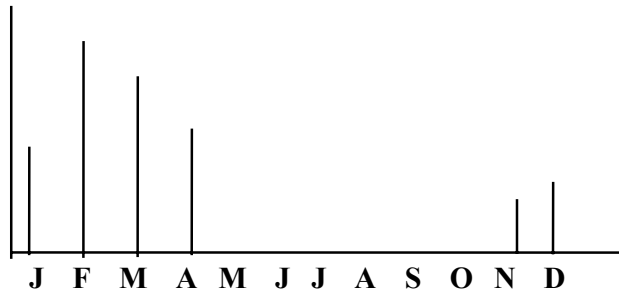

Reference for the above section on Kakamega: 'Bee-Keeping in Kakamega Core Target Area' ABLH report no.15 of 1996.

Example 3: The Beekeeping year in Molo:

Molo is an example of beekeeping in a highland area where potential is lower than other areas due to high altitude. However with good management of bees, combined with good weather conditions, yields of up to 20kg per hive are achievable (a very good yield for this area). In poor seasons and poor management yields of as little as 3kg per hive have been obtained.

Beekeeping in the area has lagged behind for many years. The following are the major problems:

- There are few flowering plants and shrubs to produce nectar
- Vast acreage's have been turned to large scale farming reducing the natural flowering vegetation.
- There is a lack of knowledge on the management of beehives.
- The cold climate in the area makes bees abscond or leave the hives.
- There is a reluctance of farmers to get into beekeeping probably due to the above factors.

Table 3: Plants suitable for bees in Molo:

Plant name:	Flowering time:
<i>Dombeya goetzentii</i>	September/October
Bottle Brush (<i>Callistemon citrinus</i>)	June /July/August
Sege brush	August/September/October
Dahlia	February to April
Maize	August to September (Pollen Only)
<i>Eucalyptus saligna</i>	February to April
Vernonia	July/August/Sept
Papaw	August/September
Wild rape	July/August
<i>Croton megalocarpus</i>	March/April
Fuchsia (ladies ear drop)	All year round except April/May and June
Daisy	February/March and August/September

Please note that the above table is a guide only. Depending on the season plants may flower late or not flower at all.

The honey harvest season in Molo is towards the end of September/October from the Dombeya tree which flowers around this time.

Example 4: The Beekeeping year in Transmara:

This is a good beekeeping area. There are many trees and shrubs that grow in the district which have not been cultivated. Natural vegetation has remained relatively undisturbed. The farmers are organised into groups and most of the hives are owned by groups and not individuals. They are co-ordinated by an umbrella body called the Transmara Association of Beekeepers.

Usually beekeepers harvest three times a year - March, July and November. From each harvest about 10kgs of honey is expected per hive. The main honey flow is in November. Apart from these times honey may also be harvested in the other months.

Table 4: Plants suitable for bees in Transmara: (*Massai names may not be spelt correctly*)

Plant name:	Flowering time:
Oskett (Massai)	May-September
Ogilai	May-September
Olmolongina	May-September
Oltorioi	June - August
Orkikeorgos	June - August
Olkinyei	November to February
Okilenyai	Nov-Feb
Olkel	Nov-feb
Olchartuyian	June to August/Nov-Feb
Olmesuli	June to August/Nov-Feb
<i>Olea africana</i> (Wild olive)	June to August/Nov-Feb
<i>Thurnbegia atela</i>	June to August/Nov-Feb
<i>Scutia myrtina</i>	June to August/Nov-Feb
<i>Cardia moncica</i>	June to August/Nov-Feb
<i>Acacia seiberiana</i>	June to August/Nov-Feb

Thanks to Baraka College for the above sections on Molo and Transmara.

Example 5: The Beekeeping year in Nandi Hills:

Some of the major flowering/honey producing trees and plants in Nandi hills are:

- Avocado- Flowers March /April
- Dombeya- April, September to December
- Grevillia robusta
- Banana- All year round

Papaw- All year round
Beans- April/May and September/October
Weeds- Always
Coffee
Sydney blue gum
Tebesuet (Nandi)
Croton macrostachyus - November to February

Honey harvesting:

April to June is the best season. It is also possible to harvest honey between October to February.

An example harvest season by J. Muemah, Nandi Hills:

In April I harvested 33kgs of crude honey from one hive. After two months, in June, I harvested a further 15kgs of crude honey from the same hive. This gave a total of 48kgs of crude honey. After refining the honey combs I got 24kgs refined honey and 1.5kgs of beeswax. From the 24kgs of honey I filled 48 500g jars for sale. Each of the 48 jars I sold at 120ksh each. This gave me revenue of 5,760ksh (\$80) from the one hive.

However, the above yield per hive is not always obtained. Another time I harvested 16 colonies and only got 67kgs of crude honey. Eight of the colonies were strong and eight were weak. This is why it is very important to manage the bees properly. With proper knowledge and management of all colonies it is possible to have all colonies give the maximum yield.

Thanks to J. Mwema for the above section on Nandi hills.

Note: The above example is an interesting one. Eight colonies in the apiary were strong and eight were weak. This situation is common. In many apiaries only a few colonies out of many give significant yields. It should be the aim of all beekeepers to make sure that all colonies are strong and producing honey if the enterprise is to maximise profits. Get rid of weak and unproductive colonies and divide productive colonies to replace them. Combine this selection of the best bees with good bee management.

Note: for more information on beekeeping in NAKURU see the Apiconsult web site where you can find regular updates on what is happening in the writer's apiary through past editions of the apiconsult e newsletter - see www.apiconsult.com and click on the news and articles section.

Bee-Keeping Management during the Year:

From the above examples it can be realised that conditions for bees vary widely throughout the country. It can be seen that management of the bees depends on where they are found. It is very important that the beekeeper gets to know the area in which he/she lives. What are the plants and trees that bees use? When do they flower? When are the swarming seasons? Which trees/plants give the best honey and which give a bitter honey (some do)? When are the right

times of the year to expect honey and which are the signs of harvesting? What factors such as rainfall and temperature affect plant flowering and nectar secretion? Collect and write down this information, it is very important in helping you to become a good beekeeper. Be observant always of your bees and the environment in which you live. Such knowledge will allow you to make timely and sound decisions on bee management.

Most bee-keepers in Kenya do not actually manage their bees at all. Every time a beekeeper is seen to go near a hive with a bee-suit he/she is said to be going to harvest. *Unaenda Kuvuna?* 'Are you going to harvest?'

Traditional hives with a fixed comb makes management very difficult. A top bar hive makes management far easier. Seek further advice on management of bees and read as much as you can on the subject. Outlined below are some simple practices which you can carry out to begin with which will help you improve your yield of honey.

Swarm prevention and control:

Swarming is when bees divide themselves to reproduce. If swarming occurs:

- a) when the bees are building up in numbers
- b) during a nectar flow (when there are allot of flowers around)

the beekeeper will not get much honey. This is because the bee population in the hive will have reduced dramatically when the bees are required to collect nectar to make into honey (look again at figure 12). Therefore, the beekeeper should try to keep his/her bees from swarming. It is impossible to prevent all swarming but with management of the bees it can be minimised and controlled.

You can take some simple steps to help stop swarming:

- a) Examine the bees weekly during the honey period (when the flowering season is about to start until after harvest).
- b) Make sure that the Queen has enough room to lay eggs by making extra space around the brood nest. If the Queen runs out of cells to lay eggs in, the bees will want to swarm. Do this by exchanging empty combs with those filled with honey around the brood nest.
- c) If the bees are building queen cells (long thumb shaped cells protruding from the edge of the combs) to make a new Queen then you know that they are going to swarm. To prevent swarming you can do one of the following:

- I. Destroy all queen cells in the colony wanting to swarm and switch hive locations with a weaker colony. The foraging bees of the strong colony will return to the original site of the hive and strengthen the weaker colony. Thus the weaker colony becomes stronger and the strong colony has become weaker. This may control the swarming urge of the strong colony.
- II. Destroy all queen cells and give brood combs without bees to the weak colony. This may get rid of the swarming urge in the strong colony.
- III. Artificially swarm the bees (**make a division**, see diagram below).

Making a division:

- 1) Break down all the queen cells except one.

- 2) Transfer the comb with the queen cell plus one other comb of brood, plus two combs of food (honey and pollen), into a catcher box/new hive. Include bees on all the combs. Shake in bees from other combs as well. Remember to put the brood combs in the middle and the honey combs on either side to insulate the brood nest.
- 3) Move the catcher box/new hive to a new site at least 2kms from the old site. These bees will become a new colony. The rest of the bees will continue working and a new Queen will hatch out in the new colony. (note: it is not always practical to move the new colony 2kms – the division can still work if you move the new colony a short distance but you can expect adult foragers to return to the site of the old hive and weaken the new colony).
- 4) Most of the adult bees will remain in the old hive and continue to make honey. However, try and avoid making divisions during the honey season because it will reduce the amount of honey produced. Make divisions after the honey flow to increase colony numbers. You can make a division without queen cells as long as the new colony has eggs in the combs transferred then they will be able to make a queen cell and raise a new queen.

Feeding

In general feeding bees is not recommended. You can waste a lot of money buying sugar to feed bees when you need it for yourself and your family. Often people feed when it is unnecessary and get no return for their money. Or the bees can simply fly away and your money is wasted.

However, if want to take a chance, the best time to feed bees is:

- a) Before a nectar flow when the Queen will lay her eggs and the colony will build up in numbers before the honey flow. Start 6-8 weeks before the date of flowering because it takes 6 weeks from egg to adult foraging bee.
- b) Or in times of food shortage such as a drought or an excessively wet and cold period. Feeding at such times may prevent the bees migrating.

To feed bees dissolve (heat gently in a *sufriah*) two parts of sugar and one part water together and place in a feeder box in the hive. Place some twigs/grass on the surface of the floating syrup to prevent bees drowning.

Warning: Never spill sugar syrup or honey around the apiary as it can start robbing. This is where bees attack each other to rob stores of honey. Weak colonies are prone to robbing by the strong.

Pests and diseases and their control:

For the most part, beekeepers need only worry about the major pests:

1. Ants,
2. Honey badgers,
3. Wax moths
4. Man

Wax Moth

Destroys the wax.

Control by having a strong colony. Remove old combs that the bees are unable to cover in time of food scarcity when the colony size shrinks. Avoid holes and cracks in top bars and hive body where wax moths can lay eggs.



Photograph 20 - this hive was infested with wax moth after the bees absconded during the dry season

Safari & other Ants

Hang hives and grease hanging wires regularly.
Spread ashes around the posts holding hives.
Keep grass short and branches from touching the hives. Make hive parts to fit together without gaps. If hives are on stands, place the legs of the stands in tins of old engine oil

Termites

Treatment of posts used for hanging

Hive Beetles

Use of holes instead of slits for the entrance.
Hand pick or destroy them if found in hive.

Birds (Honey guides)

Don't leave brood combs exposed. Scare birds away.

Honey Badger

Hang the hives securely to prevent the badger knocking them down. Hives placed on stands are prone to attack by the honey badger. In Transmara, log hives are suspended 2 meters from the ground by means of a twisted bark rope to prevent damage from the honey badger.

Pirate Wasp	Attacks and eats bees. Place a dish of water below the hive entrance which has a mirror in the bottom. Wasps fly in and drown.
Bee Louse	Negligible damage.
Man	In Kenya people cause allot of damage to hives. Hives and honey are often stolen making it difficult to keep hives in areas where security is poor. Children often antagonise bees by throwing stones at beehives which often results in people and livestock being stung. Always try and keep your hives where they can be supervised. The problem is worse with modern hives kept close to the ground.

Major nectar bearing plants in Kenya:

Many trees, shrubs and crops useful for bees in Kenya are written elsewhere in this manual however below is a consolidation of the major ones. Planting multi-purpose bee forage trees is a good idea for farmers as you can benefit from the bee forage plants in other ways such as fencing posts and firewood. Suitability of tree species for planting vary widely in Kenya due to the variation in climate. To find out which are the best species to plant seek advice from your local Beekeeping Officer or Forest Officer.

Major nectar bearing plants in Kenya: Acacia spp, Banana, Citrus, Dombeya, Eucalyptus (gum), Croton spp, Jacaranda, Keiapple (*Albera caffra*), Sunflower, Vetch, Rape and coffee.

It helps if you have what is called a **flowering calendar** for the area. Make this by finding out which are the major nectar bearing trees in your area and the times that they flower. Record this information carefully. It is then easy to look ahead and predict which trees will flower and the dates (they may vary from year to year).



Photograph 21 - citrus fruit in bloom



Photograph 22 - A Banana in flower



Photograph 23 - Acacia senegal in bloom



Photograph 24 - Acacia persiciflora in flower



Photograph 25 - Keiapple makes a great fence and is a good bee forage plant



Photograph 26 - Cordia africana is very attractive for bees

Part Four:

The Honey Harvest

Time of Harvesting:

- Harvest honey during dry spells, i.e. July, August, September, November, December, January, February and March. The harvest time in each area differs however so check which is the right time in your area.
- In areas where there are dominant bee plants, like coffee, sunflower etc., harvesting should be done after the flowers have withered.
- Regular weekly inspection of hives during the nectar flow will ensure that the beekeeper harvests as soon as the honey is ready (do not harvest unripe honey, see below)
- Ideal harvesting time of the day should be from 5.30 p.m. to 7.30 p.m.

Harvesting Procedure:

- Ensure you are sting proof by putting on your protective clothing.
- You will need a smoker in good working condition and a plastic bucket with lid (must be clean and dry) for storing the honey.
- Smoke the entrance of the hive with about 8 to 10 puffs, then open the lid and smoke again. Leave the hive for a minute or two before opening the lid to allow the smoke to affect the bees. Smoke causes the bees to engorge themselves with honey making it difficult for them to bend to sting (they become too full!).
- Tap the top bars with a hive tool. A hollow sound will indicate where there is no comb.
- Remove a top bar from the hive which has no comb attached. This allows you to examine the rest of the bars in the hive. Honeycombs are usually at the end of the hive opposite the entrance. Select combs that are 3/4 or more sealed or capped full of honey (these combs are said to be ripe or have a low moisture content (<19%) which ensures that the honey will not ferment later when bottled. Leave the combs with brood and pollen for future production of honey.



Photograph 27 - harvest white sealed honey comb like the one shown above for the best honey

- When harvesting a comb:
 - 1) Brush the bees gently from the comb using a bee brush. The harvested comb can be cut from the top bar and fall into the bucket.
 - 2) Replace the lid of the bucket to prevent bees entering with the honey.
 - 3) Return the top bar, minus the comb, to the hive.
 - 4) Alternatively, place the whole comb and top bar (after brushing the bees off) in another empty hive or catcher box where it can be later taken away for comb honey. Fix a spare top bar in place of the one removed.
- Smoking is a continuous process during harvesting time to control bees. Try and avoid smoking the honey too much because it may damage its flavour.
- After harvesting, replace the first bar and cover the hive with the lid.
- Make a final smoke before you leave to keep the bees away from the harvester and to prevent them from following you all the way home. Remember move through a bushy area first to get rid of following bees.

Note; Two people are better than one when harvesting or carrying out any bee operations. Also two smokers in operation are better than one to make sure there is a continuous supply of smoke to subdue the bees. Sufficient smoke is very important when working aggressive bees.



Photograph 28 - harvesting a traditional log hive in Tabora Tanzania



Photograph 29 - honey harvested from the log hive above placed in a clean bucket ensuring the quality of the honey is high

Honey Refining:



Photograph 30 - cleanly harvested honey without dead bees, brood, dirt etc



Photograph 31 - A simple honey refining method for the small scale beekeeper

- Remove the wax capping from the combs using a knife to cut off the cappings.
- Break the combs into smaller particles, and sieve them through a net or a nylon fabric into a plastic container (See photo 31 above). The sieving process can take a few days. Cover the honey being sieved with a lid and keep away from bees in a dry room.
- The bucket can be placed in the sunshine for two or three hours to gently heat the honey so that it flows freely.
- A word of warning - NEVER boil honey as this destroys its flavour and medicinal characteristics!

- Once the honey has drained through the cloth and settled at the bottom of the bucket (usually after 2 days or so), use a jug to pour it into honey jars for sale. For the wax remaining behind on the straining cloth squeeze out any remaining honey and process the left over wax as below.



Photograph 32 - a centrifuge which can handle honey from the KTBH (placed in baskets) as well as the Langstroth hive

Extraction of Beeswax¹:

- Mix combs and water in a *sufuria* (a large aluminium pot) and heat. Wax melts at about 60 degrees centigrade so there is no need to boil. Boiling damages the wax and can be dangerous. Overheated wax can burst into flames. Do not use iron, brass, zinc or copper containers for heating wax as it can discolour the finished product.
- Pour the melted combs and water into an extraction bag made of cotton for sieving.
- Smear the sides of a second *sufuria* with soapy water to prevent the wax sticking to its sides.
- Filter the wax into the second *sufuria*. Use two sticks (such as two top bars) to squeeze the bag containing the melted combs to extract the wax. The yellow wax will come out along with water. The waste will remain in the filter bag. If the combs had contained bee brood then these, by now cooked, can be fed to poultry.
- After filtering, the wax separates from the water and floats on top.
- Remove the wax after leaving it to cool in the *sufuria* for 12 hours.
- Scrape dirt from the bottom of the wax cake when it has cooled.
- Store wax blocks in a cool dry place. Never store beeswax near pesticides/chemicals as they may be absorbed by the wax.

¹ For every 100kg of honeycomb you can get about 8-10kg of beeswax.

- Your wax block is now ready for sale or for further use.



Photograph 33 - the solar wax melter used to extract beeswax using the sun's energy

Part Five:

The Market for Bee Products



Photograph 34 - most people enjoy honey!

A. Honey:

Currently there is a very high demand for honey both at home and overseas. Good quality honey can fetch a high price. Any farmer who has the good fortune and the skill to obtain honey will have no trouble selling it. In general, if the honey is presented to the consumer in a clean, unspoiled condition, the price will be higher. Beekeepers should aim for the highest grade of honey to maximise returns from beekeeping. Honey in Kenya is sold in the following grades:

Crude honey

This is a mixture of ripe and unripe honey. At harvesting time, the wax, honey comb, bees and brood comb are all mixed into one container. This container is often an old tin.

Crude honey is used mainly for brewing local beer and the quality requirements are not very strict. The demand for this type of honey is high.

Semi-Refined Honey

Semi-refined honey is generally the liquid honey that remains when the wax is skimmed off the top of crude honey. The honey sinks to the bottom as it is heavier.

Semi-refined honey still contains particles of wax and other debris such as bee's legs.

Semi-refined honey can be stored for the bee-keeper's own use or it can be refined further and packed for sale. It gains a higher price than crude honey.

Refined honey

Refined honey is clean. It is strained to remove all particles of beeswax and other material. Remember: refined honey is unchanged; it is only strained; nothing else is added so it is still the pure honey which the bees made in the hive.

Chunk honey

Whole combs of capped honey can be carefully harvested from the beehive. Pieces of the comb can be cut up and put into jars of liquid honey. This gives the consumer the feeling that the honey is real and not adulterated with sugar. Chunk honey can fetch a higher price than refined honey.

Comb honey

Honey combs of capped honey which have a nice white capping can be cut up and placed on small trays and covered with cling film. These are very marketable in Kenya and command a very high price in the market in particular in the affluent suburbs of Nairobi and other towns. This product should be the ultimate aim of all beekeepers with access to these markets. This product is priced per gram.

Packaging and labelling

Package honey in either plastic or glass jars which should be clean and dry. 454g jars are available in Kenya from suppliers in Nairobi as are plastic trays for selling comb honey. (see appendix 5 for the contacts of suppliers).

Labelling must include:

1. the net weight of honey,
2. the name and address of the producer,
3. the country of origin (Kenya) and
4. a description of the contents, i.e. 'Pure Honey'.

Initially, you can draw out a simple label by hand or on a computer. This can be photocopied. Later you can have a more attractive label printed, but this is costly and requires a lot of jars to be produced to spread the cost.

Kasuku/Kimbo plastic containers or tree top bottles (700mls) are often used to sell honey. **Metal Paint tins** (*Mikebe ya rangi*) **are not good**. Honey is acidic and can eat the metal and spoil the honey.

Where to sell the honey:

You can sell your bottled and labelled honey direct to shops. Try and build up a name for supplying the right quality, in the right quantity at the right price on time.

Many beekeepers develop a reputation for beekeeping and people flock to the beekeeper's home to buy the honey direct. If you are enterprising you can even set up a shop of your own selling bee products. Then you could also buy and sell honey from other beekeepers. A shop (or kiosk) located in the right place such as the market or along a busy route can attract a lot of customers.

You can also consider the option of forming a beekeeping association to market the bee products of farmers in your area. An example is the Kakamega Forest Beekeepers Association or the Transmara Association of Beekeepers (TAB).

Also you can consider the option of starting a co-operative. An example of a successful beekeeping co-operative is Ruai Beekeeping Co-operative Society, Naru Moru, (see appendix 5) which markets 8 tonnes of honey collectively per annum.

The advantage of farmers marketing together is that if such fixed costs as transport are required then these costs can be spread over a larger quantity of honey reducing cost. Collective selling gives farmers access to further away higher priced markets such as Nairobi.

In summary, whatever type of honey you produce you can easily find a market for it in Kenya and the price you will receive compares favourably with prices available elsewhere in the world.

B. Beeswax:

Unfortunately in Kenya most wax combs are thrown away on harvesting or after honey extraction. This is because beekeepers in general do not know its value. Local village uses for beeswax in Kenya are limited to such things as shoemakers repairing shoes. Some Kenyan companies such as Bata shoe company and Kiwi shoe polish purchase beeswax which they often obtain from 'Miti ni Dawa' (honey beer) brewers. The wax is left over after beer is brewed from crude honey which contains honey combs.

Baraka College (address in appendix 5) buy clean beeswax cakes among other buyers. You can also use your beeswax to make some of the recipes in appendix 4 such as candles.

C. Propolis:

Export markets for propolis do exist (see appendix 5 for the address of a buyer). Propolis is used as a medicine and is sold in capsule form, as an ointment or as a tincture (dissolved). Propolis can also be chewed raw as a medicine for the throat and is on sale in very limited quantities in this form in Nairobi. When harvesting simply scrape off the propolis and store it in an airtight container. You can also try making some medicine from propolis such as propolis ointment. Try the recipe in appendix 4.

Contact Baraka College for further information on propolis. A propolis buyer based in the UK is listed in appendix 5.

Part Six:

Starting a beekeeping enterprise - costs and profit

The figures are based on 20 KTBH hives per farmer and are valid for 2006. Equipment costs are based on the National Beekeeping Station's bee equipment workshop, Nairobi (Nyuki newsletter, December 2005).

The farmer can add significant value if he/she sells honey in Jars or bottles. This is realistic in many parts of Kenya where there is a very strong local demand for honey with high prices. In other parts of Kenya where the local production is high sale of semi-refined honey in bulk at a lower price to middlemen is the norm. In remote areas of the country honey prices tend to be low but hive numbers are much higher – in particular in semi-arid areas where individuals can own hundreds of traditional fixed comb hives.

An average production figure of 20kgs per occupied hive is an achievable figure for most farmers. However this could increase to 30kgs or more per hive depending on the area and the management of the bees. In particular if swarming is controlled and production of honey maximized. An occupation rate of 80% would mean 16 hives out of the 20 are in production which is a good occupation rate by Kenyan standards. Having said that there is no reason why 100% occupation rates cannot be achieved with some effort on the part of the farmer to ensure hives are occupied.

In this example we take an average farmer with 20 KTBH hives with an 80% occupation rate producing an average of 20kgs per occupied hive. The farmer harvests and sells the honey in bulk at a price of 100Ksh per kg with no value addition. This example is not the best farmer or the worst but an average situation.

Table 5: Costs of starting a 20 KTBH beekeeping business

A. Expenditure:	Cost (Ksh)
Cost of buying 20 Kenya top bar hives @ 1,650 each	33,000
Cost of buying a bee suit @ 2,370	2,370
Cost of buying a smoker @ 500	500
Cost of hanging posts (25) @ 150/post	3,750
Labour @ 5ksh/kg harvesting 20kg/hive/16 occupied	1,600
Cost of grease and other miscellaneous	500
Total Expenditure:	41,720

- Estimated honey production from one colony = 20Kgs
- Total honey production from 16 occupied hives = 320kgs
- Estimated price of one Kg of honey in 2006 = 100ksh/kg
- **Estimated income** from 16 occupied hives = 32,000Ksh

Net Income year one = 32,000 - 41,720 = (9,720) A negative of nine thousand seven hundred and twenty.

Equipment will have a life span of 5-10 years or more depending how it is cared for so in second and subsequent years capital costs have been paid and net profit from the enterprise will be much higher as seen below. The question is how do poor farmers finance the capital costs to get started? The important thing in beekeeping is that a farmer can start beekeeping using simple hives made from local materials (such as the mud stick hive/or simple box hives/pots etc). Therefore it is not necessary or advisable a farmer takes a loan to get started (unless you are absolutely sure you can make the hives produce for you – this certainty comes from experience). Start slowly, learn as you go along and once you understand what you are doing expand. Many farmers in Kenya who have purchased expensive frame hives on loan have ended up repaying the loan from other means as the hives have not produced anything – this is very demoralising. In particular with the recent promotion of the Langstroth hive – there is a belief that the hive will automatically produce honey and lots of it – **BE WARNED THIS IS NOT THE CASE!!** The Langstroth will only yield well with good management.

Gross Margin Analysis:

The following is an analysis of beekeeping versus a major other source of livelihood in Kenya, maize production. The figures for maize production are from the Mount Elgon District Farm Management Guidelines (Obino 2004). The figures used for beekeeping are from an apiary in Nakuru district Kenya.

The table below looks at the same beekeeping enterprise above minus the capital costs. It also looks at the enterprise at different production levels – low, medium and high. Low is 10kgs per occupied hive/annum. Medium is 20kgs per occupied hive/annum and high is 30kgs per occupied hive/annum. The sale price of honey is estimated at 100ksh/kg. This price can easily be increased through value adding to the honey by packaging. Indeed many farmers in Kenya can sell honey in raw form for 150Ksh per kg or more to their neighbours – e.g. beekeepers in Lare area of Nakuru District.

Table 6: Gross Margin analysis of beekeeping

Description	Production Level		
	Low (10KGS)	Medium(20KGS)	High(30KGS)
A. Production			
a) Yield per hive x 16	160	320	480
b) Price per Kg honey	100	100	100
Gross Output (a x b)	16,000	32,000	48,000
B. Variable costs			
Labour	1,000	1,500	2,000
Grease and other Miscellaneous	500	500	500
Total Variable Costs	1,500	2,000	2,500
Gross Margin/16 occupied hives	14,500	30,000	45,500

Table 7: Gross Margin for a Hectare of Maize (Pure Stand): (Obino 2004)

Description	Production Level		
	Low	Medium	High
A. Production			
a) Yield of maize (90kgs bag)	20	50	87
b) Price of maize	1,100	1,100	1,100
Gross Output (a x b)	22,000	55,000	95,700
B. Variable Costs			
Total variable costs	18,111	26,273	50,707
Gross Margin/Hectare	3,889	18,728	44,994

Source: Kenyan Ministry of Agriculture

From the above comparison a beekeeping enterprise of 20 KTBH hives compares very favourably with returns from a hectare of maize (in particular at low levels of efficiency in maize production). In addition a beekeeper has the option of value adding to his/her honey to increase returns while a maize farmer is more at the mercy of market forces where gluts in production frequently depress prices.

Appendices:

Appendix 1: The current status of the Kenyan Beekeeping Industry

The majority of Kenyan beekeepers still use traditional systems of beekeeping. These are simple fixed comb, mostly hollow log hives. This is in spite of over 30 years of beekeeping extension carried out by Government and Non Governmental Organisations (NGO's) to promote improved hives – mostly the Kenya Top Bar Hive – an intermediate technology hive.

In the last 5 years there has been a major push by some NGO's, and private companies and supported by major donors to introduce the Langstroth frame hive, used in Europe and America. There is conflicting information on the impact of these hives with those promoting the hives claiming success. However information collected in a number of recent beekeeping studies indicate limited impact on enhanced production of bee products and improving beekeeper's livelihoods.

Conflicting information on different production technologies also results in confused farmers who are receiving different messages from different extension agents.

In relation to bee product marketing, information collected indicates that the Kenyan honey market is under developed due to low volumes and that volumes and quality have not been reached for export. Kenya has been licensed to export honey to the European Union since 2003, however no honey has yet been exported because of a shortage of bee product production which is currently insufficient to meet local demand with significant quantities of imported honey in the Kenyan market – much of this from Tanzania and repackaged as Kenyan honey.

Opportunities exist for the development of Fair Trade and Organic honey export markets due to Kenya's largely pollution free environment and disease free bees.

It is reported that local production of honey has improved in recent years due to reduced official honey imports. However this may be explained by an increased cross border trade in honey, mostly from Tanzania, not captured in official statistics, marketed as Kenyan honey on local markets.

Other issues of importance affecting the Kenyan beekeeping industry include:

- There is a lack of a clear Government beekeeping policy (which is now under development). Different agencies take different approaches to beekeeping with no national coordinating body resulting in a disorganized and fragmented industry.

- Environmental degradation is a major issue – mostly forest destruction/charcoal burning which is resulting in a reducing beekeeping potential in Kenya.
- There is little or no beekeeping research in Kenya
- Beekeepers are often fragmented and disorganized and difficult to reach due to poor infrastructure resulting in difficulties in bulking honey for marketing.

June 2006

Appendix 2: More information on stingless bees

Apart from honeybees (*Apis mellifera*) there are other types of bees in Kenya which collect nectar and make honey. These are stingless bees which usually live in holes in the ground. There are many species of stingless bees (*Meliponula*) in Kenya and these are yet unexploited on a commercial basis. In Brazil and India these bees are exploited because of their ability to make good quality medicinal honey. This honey is prized as a cure for baldness and is said to reduce impotence. These bees can yield up to 5kgs per season. Stingless bees are known to be the best pollinators as they are able to penetrate deeper into the flower. Baraka Agricultural College, Molo and also the National bee station at Lenana, Nairobi have started keeping stingless bees. Stingless bees can be kept in small hives. The bees store their honey in small pots which can be harvested daily with a clean syringe!



Photograph 35 - a simple box hive for stingless bees at Baraka Agricultural College, Molo



Photograph 36 - the hive has a glass cover with a lid as the bees require darkness

Appendix 3:

Hive Record Keeping

Hive No.	Occupation date	Date of inspection and comments	Harvesting date	Amount crude honey (kg)	Amount refined honey (kg)	Amount of bees wax (kg)	Remarks

You can make out the above table in a hard back note book which you should fill out after inspecting each hive. In the remarks section you can specify the inspection date and any information of use such as the temperament of the bees i.e. are the bees docile or are they difficult to handle? This information is useful when selecting bees in the future. Any management activities can be recorded here such as: (a) the amount the bees were fed (if any) and (b) the cost, what action was taken to control swarming etc.

Marketing Records:

Date	Amount of honey sold (kg)	Price per kg of honey	Total Revenue

Appendix 4: Recipes/uses for beeswax, propolis and honey



Photograph 37 - The Kenyan National Beekeeping Station's stand at a recent exhibition displaying many excellent products of the bees

A. Beeswax Furniture/Wood Polish:

Ingredients:

200g Beeswax
100g Turpentine
50g Baby oil

Grate the beeswax into flakes. Gradually add the turpentine to soften the wax. Add oil and mix. Store in a tin, with a tight fitting top, or in a jar.

2) Sewing - shoes, leather and other thick material.

Pull the thread through a small block of beeswax. The wax stiffens and smoothes the thread making it easier to sew.

B. Making Beeswax Candles:



Photograph 38 - a selection of beeswax candles made at Baraka Agricultural College, Molo, Kenya

Requirements:

Beeswax, wick (use cotton thread), a bottle top, plastic pipe which can fit into the bottle top, some cooking oil.

Procedure:

1. Smear the inside of the plastic pipe with soapy water or cooking oil
2. Thread the wick through the pipe.
3. Punch a hole in the middle of the bottle top and thread the wick through the hole and knot it.
4. Melt your beeswax indirectly i.e. using a double pan (one 'sufriah' sitting in hot water inside another 'sufriah'). Do not boil the wax.
5. Cover the bottom end of the pipe (to prevent the wax flowing away) by pushing it down into the bottle top – you can also stick the end of the pipe in the ground.
6. Tie the wick to the suspension wire.
7. Pour some melted wax into the mould making sure the wick is in the middle of the candle. Wait for the wax to cool before filling the rest of the mould with molten wax.
8. Leave the candle to become solid. It should then come out easily from the mould because the mould was greased with the cooking oil.
9. Your candle is now ready for use. Vary the wick to get a good candle that burns well.
10. To speed up the process, use many plastic pipes to make many candles at the same time.

Figure 18: Candle making

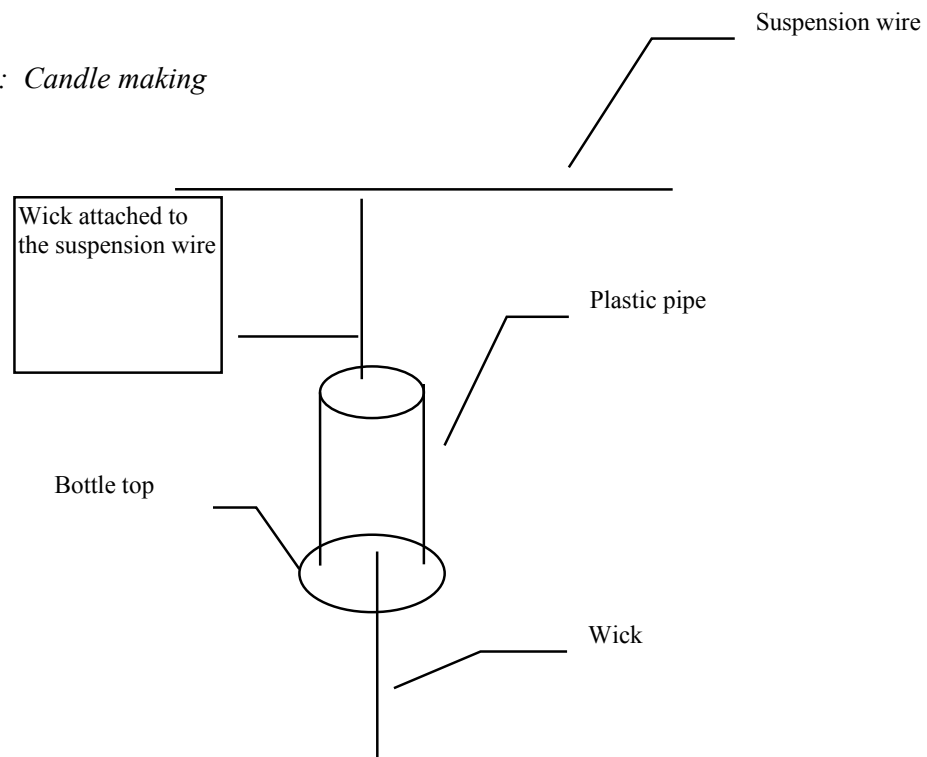

Photograph 39 - beautiful beeswax candles made using a plastic pipe mould

C. Propolis Ointment:

The first stage is to make propolis granules:

Step 1:

- go to your hives and scrape off the propolis, putting the scrapings in a tin.
- add enough water to cover the scrapings and heat
- wax will melt and float to the surface
- propolis will stick to the bottom of the can
- stir often to help release the wax
- remove from the heat and let cool

Step2:

- remove the waxy layer formed on the water surface
- pour off the water and save the coloured mass beneath

Step 3:

- place the can in a cool place where the propolis will harden and become brittle (freezer best)
- dry and store in a sealed container

Propolis healing ointment:

- 1 tablespoon of beeswax
- 4 tablespoons of mineral oil (e.g. baby oil)
- 1 tablespoon of propolis granules
- 1 tablespoon of honey

Melt the ingredients in a double boiler. Stir until it cools. It should then have the consistency of a cream. You can pack in small containers and sell. Use the cream as a skin ointment for sores, rashes, blisters etc. Many farmers groups we work with are now making and selling beeswax and propolis creams and making good money from this activity – for more information contact Baraka Agricultural College (see contacts in appendix 5).

D. Honey cough syrup:

Ingredients:

1. 6 tablespoons of pure honey
2. Juice of 2 lemons

Mix the ingredients together well before taking in spoonfuls for coughs.

Warning: Be careful when working with hot wax and other ingredients used to make these recipes – the author can not be held responsible for adverse effects resulting from the use of methods or ingredients mentioned in this publication.

Appendix 5: Sources of Further Information

A. In Kenya:

As a starting point for anyone looking for further information on beekeeping in Kenya, the following organisations can be contacted. There are many others involved in beekeeping and the number changes all the time. This list is not an exhaustive one and is just intended to be a starting point for further networking.

1. Baraka Agricultural College, P.O Box 52, Molo. Phone: 051 721091 - Bee equipment, advice, training courses, honey and beeswax marketing. Email baraka@sustainableag.org Web site: www.sustainableag.org
2. National Beekeeping Station, Apiculture and Emerging Livestock Division, Ministry of Livestock & Fisheries Development Lenana, P.O. Box 34188, Nairobi, KENYA. TEL.NO. (020) 564302- library, bee equipment and advice.
3. Ruai Bee-Keeping Co-operative Society, P.O. Box 8, Naru Moru - great example of collective marketing of bee products in Kenya - market up to 8 tonnes of honey per annum.
4. ICIPE (International Centre for Insect Physiology and Ecology), P.O.Box 30772 - 00100Nairobi. Phone: (020) 8632000. Fax: +254 (20) 8632001/8632002 Has a commercial insect section dealing with beekeeping E-mail: dg@icipe.org
5. Organisation for African Unity - Mandaleo Ya Wanawake House, Nairobi has an interesting collection of beekeeping books in their library.
6. General Plastics Limited, P.O.Box 10032, Nairobi. *PHYSICAL ADDRESS* : Enterprise Rd Off Mombasa Rd Industrial Area near Hillock Inn Phone: (020) 530032/3/4/5 - Supply plastic jars and lids for packing honey.
7. Honey Care Africa – Muringa Avenue, Jamhuri Park, Nairobi, Phone: (020) 574448 – promote Langstroth hives – buy and market honey.
8. Kenya Honey Council, Box 271, Sarit Centre, Nairobi 00606 Telephone: (020) 583120 - a representative organisation for beekeeping in Kenya.
9. Strengthening Informal Sector Training & Enterprise (SITE) TEL :(254) 202718155 Jabavu Rd, Nairobi – deal in training and support to beekeeping and bee equipment.

B. The rest of Africa:

10. Tawiri Njiro Wildlife Research Centre – Ministry of Natural Resources and Tourism – Forestry and Beekeeping Division – c/o Box 246 Dar Es Salaam, Tanzania. Email: fordev@africaonline.co.tz - Tawiri run beekeeping courses and carry out beekeeping research. Alternative contacts: **Address:** P.O. Box 661, Arusha, Tanzania. **Tel:** +255 (0) 27 7677, **Tel/Fax:** +255 (0) 27 2548240, **E-mail:** tawiri@habari.co.tz or info@tawiri.org.
11. Plant Protection Research Institute South Africa – Private Bag x 134, Pretoria 0001, South Africa www.arc.agric.za – have a very good book Beekeeping in South Africa.

C. International:

12. Bees for Development, Troy, Monmouth, NP25 4AB, United Kingdom - produce a very nice magazine. Subscriptions payable with beeswax. Also sell beekeeping books. www.beesfordevelopment.com Telephone +(44) 016007 13648 Fax +(44) 016007 16167
13. Bee Support – promotion of beekeeping for development email: micha_el@dds.nl
14. Hives Save Lives – P.O.Box Saltdean, Brighton, BN51 9AB, UK – www.hivessavelives.com
15. Bees Abroad UK – www.beesabroad.org.uk A UK based charity supporting beekeeping development
16. International Bee Research Association (IBRA) - 18 North Road, Cardiff CF1 3DY, United Kingdom - good library on beekeeping around the world and publish the Journal of Apicultural Research and Bee World – www.ibra.org.uk
17. CTA/Agromisa, P.O. Box 41, Wageningen, The Netherlands - booklets on Agriculture and bees.
18. Bee Vital – a UK based company which purchase propolis – www.BeeVitalPropolis.com

Appendix 6: Beekeeping resources on the internet:

There are a number of web sites which are of interest to beekeeping in Kenya and beekeeping in Africa and offer a large variety of resources and information. It is well worth checking out internet resources.

There is a list of beekeeping resources suitable for Africa on the links page of Apiconsult.com

See <http://www.apiconsult.com/beekeeping-links.htm>

This page is updated regularly.

In addition the Apiconsult web site has a discussion forum on African beekeeping where information is shared amongst beekeepers on the African continent. Please join the discussion and share your experiences!

As of May 2006 the following web sites are considered useful:

1. <http://www.apiconsult.com>
2. <http://www.topbarhive.com> – information on top bar hives in the USA
3. <http://www.apiservices.com> – loads of information on world beekeeping
4. <http://www.honeybadger.co.za> – a South African site on beekeeping
5. <http://www.beesfordevelopment.org> – a UK based site promoting beekeeping in development
6. <http://www.gsu.edu/~biojdsx/main.htm> - beekeeping in top-bar hives
7. <http://www.honeycarefrica.com> – beekeeping with Langstroth hives in Kenya

There are many more. A good way to generate more beekeeping links is to do a search with a search engine such as Google (www.google.com) on ‘beekeeping in Africa’ or ‘top bar hives’ etc.

Happy Surfing!!

Appendix 7: Recommended Reading/References:

The following books and publications give useful information for beekeepers in East Africa. They have also been used as reference material for this manual.

1. Adjare S., 1984, 'The Golden Insect: a handbook on beekeeping for beginners', Ghana, 104pp
2. ABLH, 1996, 'Bee-Keeping in Kakamega Core Target Area', ABLH report no.15 of 1996.
3. Beekeeper's Guide Book (2005) – National Beekeeping Station, Nairobi, Kenya
4. CTA/Agromisa, 1991, 'Beekeeping in the Tropics', The Netherlands, Agrodok 32, 83pp
5. Gentry, C., 1982, 'Small Scale beekeeping', Peace Corps USA, 212pp
6. Jones Richard (1999) 'Beekeeping as a Business' International Bee Research Association/Commonwealth Secretariat,
7. Johannsmeier, M.F. (2001) 'Beekeeping in South Africa', third edition revised Plant Protection Research Institute handbook No. 14, Pretoria South Africa
8. Kigatiira, K.I., 1982, 'Bee-Keeping For Beginners', Nairobi Kenya, 33pp
9. Ministry of Agriculture/Canadian Apiculture team (1974), 'Bee-Keeping in Kenya', Nairobi, 37pp.
10. Ministry of Natural Resources and Tourism (2001), 'Beekeeping in Tanzania' Box 9372, Dar Es Salaam, Tanzania.

Check out libraries at the National Beekeeping Station Nairobi, Baraka Agricultural College, Molo and also at the Organisation for African Unity, Nairobi for more beekeeping references.